

SH69P25

PRELIMINARY

OTP 4-bit Microcontroller

Features

- SH6610C-based single-chip 4-bit micro-controller
- OTPROM: 4096 X 16 bits
- RAM: 160 X 4 bits (data memory)
- Operation voltage: 2.4V - 6.0V (typical 3.0V or 5.0V)
- 22 CMOS bi-directional I/O pins
- Built in pull-up and pull-low resistor for PortA ~ PortF
- 4-level subroutine nesting (including interrupts)
- One 8-bit auto re-load timer/counter
- Warm-up timer for power on reset
- Powerful interrupt sources:
 - Internal interrupt (Timer0)
 - External interrupts: PortB & PortC (rising/falling edge)
- Oscillator (OTP option)
 - X`tal oscillator: 32.768kHz - 4MHz
 - Ceramic resonator: 400k - 4MHz
 - RC oscillator: 400k - 4MHz
 - External clock: 30k - 4MHz
- Instruction cycle time:
 - 4/32.768kHz(122us) for 32.768kHz OSC clock
 - 4/4MHz (1us) for 4MHz OSC clock
- Two low power operation modes: HALT and STOP
- Built-in watch dog timer (OTP option)
- Built-in power on reset
- Two LPD level(OTP option)
 - High level: 4.0V
 - Low level: 2.5V
- OTP type &Code protection

General Description

SH69P25 is a 4-bit micro controller. This chip integrates the SH6610C 4-bit CPU core with SRAM, 4K OTPROM, Timer and I/O Ports.

Pin Configuration

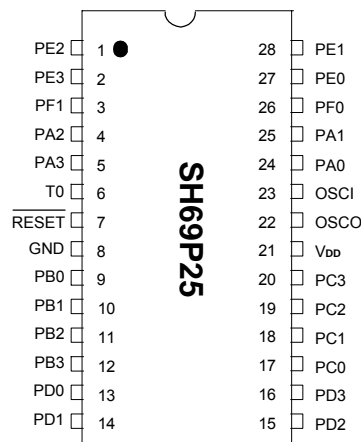



Block Diagram

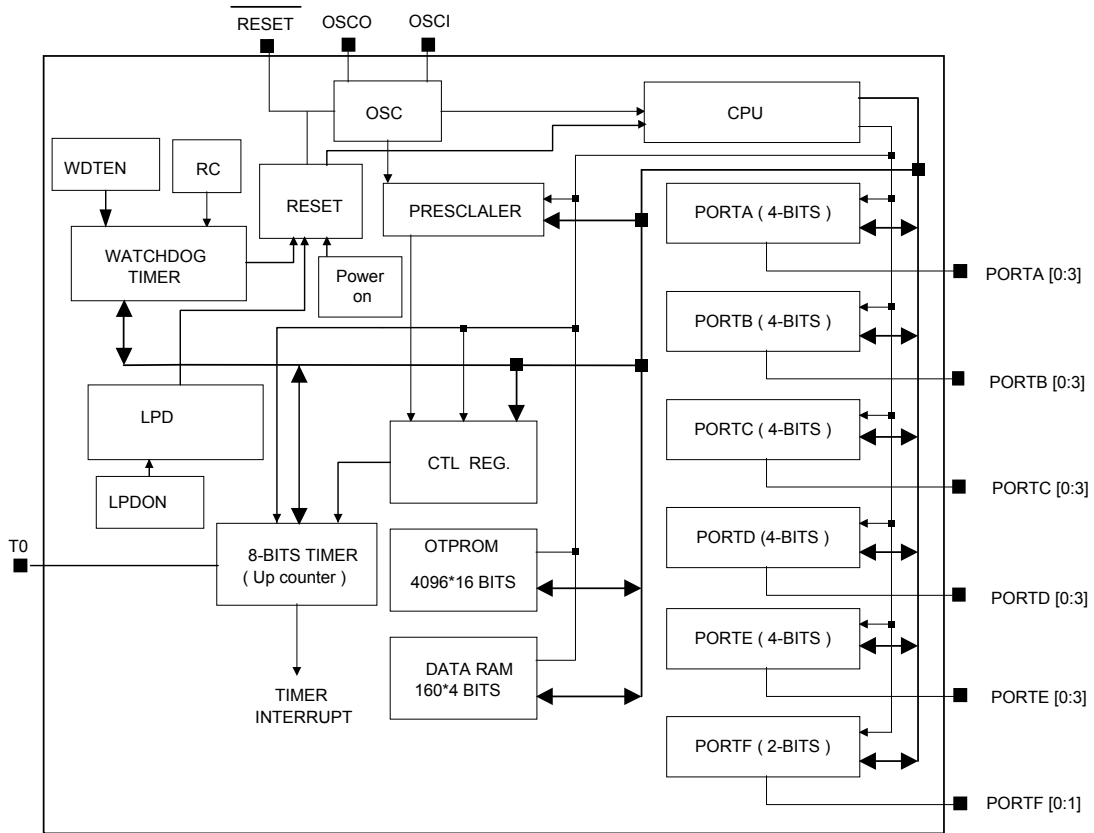

**Pin Description(Normal mode)**

Pin No.	Designation	I/O	Descriptions
27, 28, 1, 2	PE[0:3]	I/O	Bit programmable I/O
26, 3	PF[0:1]	I/O	Bit programmable I/O
24, 25, 4, 5	PA[0:3]	I/O	Bit programmable I/O.
6	T0	I	Timer Clock/Counter input pin. (Schmitt trigger input)
7	$\overline{\text{RESET}}$	I	Reset input (active low, Schmitt trigger input).
8	GND	P	Ground pin
9 - 12	PB[0:3]	I/O	Bit programmable I/O. Vector Interrupt (Active rising or falling edge by system register setup)
13- 16	PD[0:3]	I/O	Bit programmable I/O
17 - 20	PC[0:3]	I/O	Bit programmable I/O. Vector Interrupt (Active rising or falling edge by system register setup)
21	V _{DD}	P	Power supply pin
22	OSCO	O	OSC output pin. No output in RC mode
23	OSCI	I	OSC input pin, connected to a crystal, ceramic or external resistor.

OTP Programming Pin Description (OTP program mode)

Pin No.	Symbol	I/O	Shared by	Description
21	V _{DD}	P	V _{DD}	Programming Power supply (+5.5V)
7	V _{PP}	P	$\overline{\text{RESET}}$	Programming high voltage Power supply (+10.5V)
8	GND	P	GND	Ground
23	SCK	I	OSCI	Programming Clock input pin
24	SDA	I/O	PA[0]	Programming Data pin



Function Description

1. CPU

The CPU contains the following function blocks: Program Counter, Arithmetic Logic Unit (ALU), Carry Flag, Accumulator, Table Branch Register, Data Pointer (INX, DPH, DPM, and DPL), and the Stack.

1.1. PC (Program Counter)

The Program Counter is used to address the 4K program ROM. It consists of 12-bits: the Page Register (PC11), and the Ripple Carry Counter (PC10, PC9, PC8, PC7, PC6, PC5, PC4, PC3, PC2, PC1, PC0).

The program counter normally increases by one (+1) with every execution of an instruction except in the following cases:

- (1) When executing a jump instruction (such as JMP, BA0, BAC),
- (2) When executing a subroutine call instruction (CALL),
- (3) When an interrupt occurs,
- (4) When the chip is in the INITIAL RESET mode.

The program counter is loaded with data corresponding to each instruction. The unconditional jump instruction (JMP) can be set at 1-bit page register for higher than 2K.

1.2. ALU and CY

ALU performs arithmetic and logic operations. The ALU provides the following functions:
Binary addition/subtraction (ADC, SBC, ADD, SUB, ADI, SBI)

Decimal adjustment for addition/subtraction (DAA, DAS)
Logic operations (AND, EOR, OR, ANDIM, EORIM, ORIM)

Decision (BA0, BA1, BA2, BA3, BAZ, BAC)
Logic Shift (SHR)

The Carry Flag (CY) holds the ALU overflow which the arithmetic operation generates. During an interrupt servicing or call instruction, the carry flag is pushed into the stack and retrieved back from the stack by the RTNI instruction. It is unaffected by the RTNW instruction.

1.3. Accumulator

The Accumulator is a 4-bit register holding the results of the arithmetic logic unit. In conjunction with the ALU, data transfer between the accumulator and system register or data memory can be performed.

1.4. Stack

A group of registers are used to save the contents of CY & PC (10-0) sequentially with each subroutine call or interrupt. It is organized into 13 bits X 4 levels. The MSB is saved for CY. 4 levels are the maximum allowed for subroutine calls and interrupts.

The contents of the Stack are returned sequentially to the PC with the return instructions (RTNI/RTNW). The stack is operated on a first-in, last-out basis. This 4-level nesting includes both subroutine calls and interrupts requests. Note that program execution may enter an abnormal state if the number of calls and interrupt requests exceed 4, and the bottom of the stack will be shifted out.

2. OTPROM

The SH69P25 can address up to 4096 X 16 bit words of program area from \$000 to \$FFF. Service routine as starting vector address.

Address	Instruction	Remarks
\$000H	JMP Instruction	Jump to RESET service routine
\$001H	NOP	Reserved
\$002H	JMP Instruction	Jump to TIMER0 service routine
\$003H	NOP	Reserved
\$004H	JMP Instruction	Jump to PBC service routine



3. RAM

The built-in RAM consists of general-purpose data memory and the system register. Direct addressing in one instruction can access both data memory and the system register.

The following is the memory allocation map:

\$000 - \$01F: System register and I/O.

\$020 - \$0BF: Data memory (160 X 4 bits, divided into 2 banks. \$020 - \$07F: bank0, \$080 - \$0BF: bank1).

(a) The Configuration of the System Register

Address	Bit3	Bit2	Bit1	Bit0	R/W	Remarks
\$00	-	IET0	-	IEP	R/W	Interrupt enable flags
\$01	-	IRQT0	-	IRQP	R/W	Interrupt request flags
\$02	-	TM0.2	TM0.1	TM0.0	R/W	Timer0 Mode register (Prescaler)
\$03	-	-	-	-	-	Reserved
\$04	TL0.3	TL0.2	TL0.1	TL0.0	R/W	Timer0 load/counter register low digit
\$05	TH0.3	TH0.2	TH0.1	TH0.0	R/W	Timer0 load/counter register high digit
\$06-\$07	-	-	-	-	-	Reserved
\$08	PA.3	PA.2	PA.1	PA.0	R/W	PORTA
\$09	PB.3	PB.2	PB.1	PB.0	R/W	PORTB
\$0A	PC.3	PC.2	PC.1	PC.0	R/W	PORTC
\$0B	PD.3	PD.2	PD.1	PD.0	R/W	PORTD
\$0C	PE.3	PE.2	PE.1	PE.0	R/W	PORTE
\$0D	-	-	PF.1	PF.0	R/W	PORTF
\$0E	TBR.3	TBR.2	TBR.1	TBR.0	R/W	Table Branch Register
\$0F	INX.3	INX.2	INX.1	INX.0	R/W	Pseudo index register
\$10	DPL.3	DPL.2	DPL.1	DPL.0	R/W	Data pointer for INX low nibble
\$11	-	DPM.2	DPM.1	DPM.0	R/W	Data pointer for INX middle nibble
\$12	-	DPH.2	DPH.1	DPH.0	R/W	Data pointer for INX high nibble
\$13 - \$14						Reserved
\$15	PULLEN	PH/PL	PBCFR	-	R/W	Bit1:PBC interrupt rising / failing edge set Bit2:Port pull-hi/low set Bit3: Port pull-up/low enable control
\$16	PA3OUT	PA2OUT	PA1OUT	PA0OUT	R/W	Set PORTA as an output port
\$17	PB3OUT	PB2OUT	PB1OUT	PB0OUT	R/W	Set PORTB as an output port
\$18	PC3OUT	PC2OUT	PC1OUT	PC0OUT	R/W	Set PORTC as an output port
\$19	PD3OUT	PD2OUT	PD1OUT	PD0OUT	R/W	Set PORTD as an output port
\$1A	PE3OUT	PE2OUT	PE1OUT	PE0OUT	R/W	Set PORTE as an output port
\$1B	-	-	PF1OUT	PF0OUT	R/W	Set PORTF as an output port
\$1C	-	-	T0S	T0E	R/W	Bit0: T0 signal edge; Bit1: T0 signal source
\$1D	-	-	-	-	-	Reserved
\$1E	WDT	-	-	-	W	Bit3: WDT timer reset (write 1 to reset WDT)
\$1F	-	-	-	-	-	Reserved

* System Register \$00 - \$12 (except \$07H) refer to "SH6610C User manual".



(b) System Register state:

	Bit 3	Bit 2	Bit 1	Bit 0	Power On Reset /Pin Reset / Low Voltage Reset	WDT Reset
\$00	-	IET0	-	IEP	- 0 - 0	- 0 - 0
\$01	-	IRQT0	-	IRQP	- 0 - 0	- 0 - 0
\$02	-	TM0.2	TM0.1	TM0.0	- 000	- 000
\$03	-	-	-	-	-	-
\$04	TL0.3	TL0.2	TL0.1	TL0.0	0000	0000
\$05	TH0.3	TH0.2	TH0.1	TH0.0	0000	0000
\$06-\$07	-	-	-	-	-	-
\$08	PA.3	PA.2	PA.1	PA.0	1111	1111
\$09	PB.3	PB.2	PB.1	PB.0	1111	1111
\$0A	PC.3	PC.2	PC.1	PC.0	1111	1111
\$0B	PD.3	PD.2	PD.1	PD.0	1111	1111
\$0C	PE.3	PE.2	PE.1	PE.0	1111	1111
\$0D	-	-	PF.1	PF.0	- -11	- -11
\$0E	TBR.3	TBR.2	TBR.1	TBR.0	xxxx	uuuu
\$0F	INX.3	INX.2	INX.1	INX.0	xxxx	uuuu
\$10	DPL.3	DPL.2	DPL.1	DPL.0	xxxx	uuuu
\$11	-	DPM.2	DPM.1	DPM.0	-xxx	-uuu
\$12		DPH.2	DPH.1	DPH.0	-xxx	-uuu
\$13 - \$14					-	-
\$15	PULLEN	PH/PL	PBCFR	-	010 -	010 -
\$16	PA3OUT	PA2OUT	PA1OUT	PA0OUT	0000	0000
\$17	PB3OUT	PB2OUT	PB1OUT	PB0OUT	0000	0000
\$18	PC3OUT	PC2OUT	PC1OUT	PC0OUT	0000	0000
\$19	PD3OUT	PD2OUT	PD1OUT	PD0OUT	0000	0000
\$1A	PE3OUT	PE2OUT	PE1OUT	PE0OUT	0000	0000
\$1B	-	-	PF1OUT	PF0OUT	- - 00	- - 00
\$1C	-	-	T0S	T0E	- - 00	- - 00
\$1D	-	-	-	-	-	-
\$1E	WDT	-	-	-	-	-
\$1F	-	-	-	-	-	-

Legend: x = unknown, u = unchanged, - = unimplemented read as '0'.



(c) Others initial state:

Others	After any Reset
Program Counter (PC)	\$000
CY	Undefined
Accumulator (AC)	Undefined
Data Memory	Undefined

4. Low Power Detection (LPD)

The LPD function is used to monitor the supply voltage and applies an internal reset in the micro-controller at the time of battery replacement. If the applied circuit satisfies the following conditions, the LPD can be incorporated using software control.

- Power supply voltage $V_{DD} = 2.4$ to 6.0 V

4.1 Functions of the LPD Circuit

The LPD function is selected by OTP option.

The LPD circuit has the following functions:

- It generates an internal reset signal when $V_{DD} \leq V_{LPD}$ and $t \geq t_{LPD}$
- It cancels the internal reset signal when $V_{DD} > V_{LPD}$ or $V_{DD} \leq V_{LPD}$ and $t < t_{LPD}$

Here, V_{DD} : power supply voltage, V_{LPD} : LPD detect voltage, There are two level selected by OTP option:

- Low level: 2.3~2.7V, typical 2.5V
- High level: 3.8~4.2V, typical 4.0V
- t_{LPD} : 100 μ s~500 μ s, typical 300 μ s

LPD can be enabled or disabled permanently by OTP option.



5. I/O Ports

The SH69P25 provides 22 I/O pins. When every I/O is used as an input port, the port control register controls ON/OFF of the output buffer. Sections below show the circuit configuration of I/O ports.

Every I/O pin has a internal pull up / pull low resistor, which is controlled by PULLEN and PH/PL of \$15

Each of these ports contains 4 or 2(PF) bits I/O pins. ON/OFF of the output buffer for port can be controlled by the port control register. Port I/O mapping address is shown as follows:

Address	Bit3	Bit2	Bit1	Bit0	R/W	Remarks	Power On
\$08	PA.3	PA.2	PA.1	PA.0	R/W	PORTA	1111
\$09	PB.3	PB.2	PB.1	PB.0	R/W	PORTB	1111
\$0A	PC.3	PC.2	PC.1	PC.0	R/W	PORTC	1111
\$0B	PD.3	PD.2	PD.1	PD.0	R/W	PORTD	1111
\$0C	PE.3	PE.2	PE.1	PE.0	R/W	PORTE	1111
\$0D	-	-	PF.1	PF.0	R/W	PORTF	--11

Equivalent Circuit for a Single I/O Pin

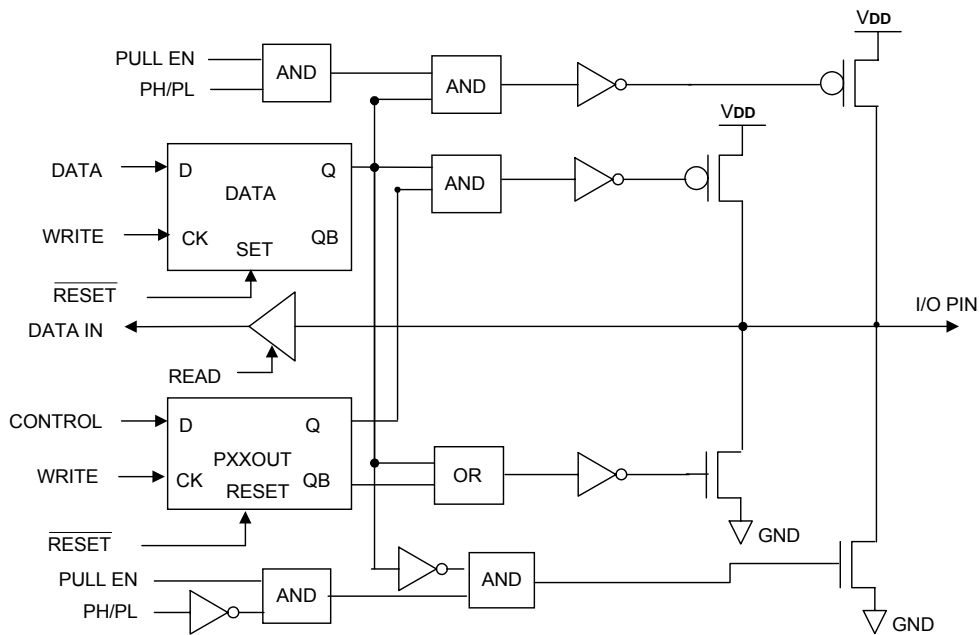



System Register \$16 - \$1B

Address	Bit3	Bit2	Bit1	Bit0	R/W	Remarks	Power On
\$15	PULLEN	PH/PL	PBCFR	-	RW	Bit1:PBC interrupt rising / failing edge set Bit2:Port pull-hi/low set Bit3: Port pull-up/low enable control	010 -
\$16	PA3OUT	PA2OUT	PA1OUT	PA0OUT	W	Set PORTA as an output port	0000
\$17	PB3OUT	PB2OUT	PB1OUT	PB0OUT	W	Set PORTB as an output port	0000
\$18	PC3OUT	PC2OUT	PC1OUT	PC0OUT	W	Set PORTC as an output port	0000
\$19	PD3OUT	PD2OUT	PD1OUT	PD0OUT	W	Set PORTD as an output port	0000
\$1A	PE3OUT	PE2OUT	PE1OUT	PE0OUT	W	Set PORTE as an output port	0000
\$1B	-	-	PF1OUT	PF0OUT	W	Set PORTF as an output port	-- 00

PAXOUT, PBXOUT, PCXOUT, PDXOUT, PEXOUT (X = 0, 1, 2, 3), PFXOUT (X = 0, 1)

1: Use as an output buffer

0: Use as an input buffer (Power on initial)

PBCFR: 1: Rising Edge interrupt

0: Falling Edge interrupt,

PH/PL: 1: Port Pull up resister ON,

0: Port Pull low resister ON,

PULLEN: 1: Port Pull up /Pull low enable,

0: Port Pull up /Pull low disable



PORTB & PORTC interrupt

The PORTB and PORTC are used as port interrupt sources. Since PORT I/O is bit programmable I/O, so only the input port can generate an external interrupt.

When PBCFR set to 0, any one of the PORTB and PORTC input pin transitions from VDD to GND will generate an interrupt request. And further falling edge transition would not be able to make interrupt request until all of the pins return to VDD.

When PBCFR set to 1, any one of the PORTB and PORTC input pin transitions from GND to VDD will generate an interrupt request. And further rising edge transition would not be able to make interrupt request until all of the pins return to GND.

Following is the port interrupt function block-diagram.

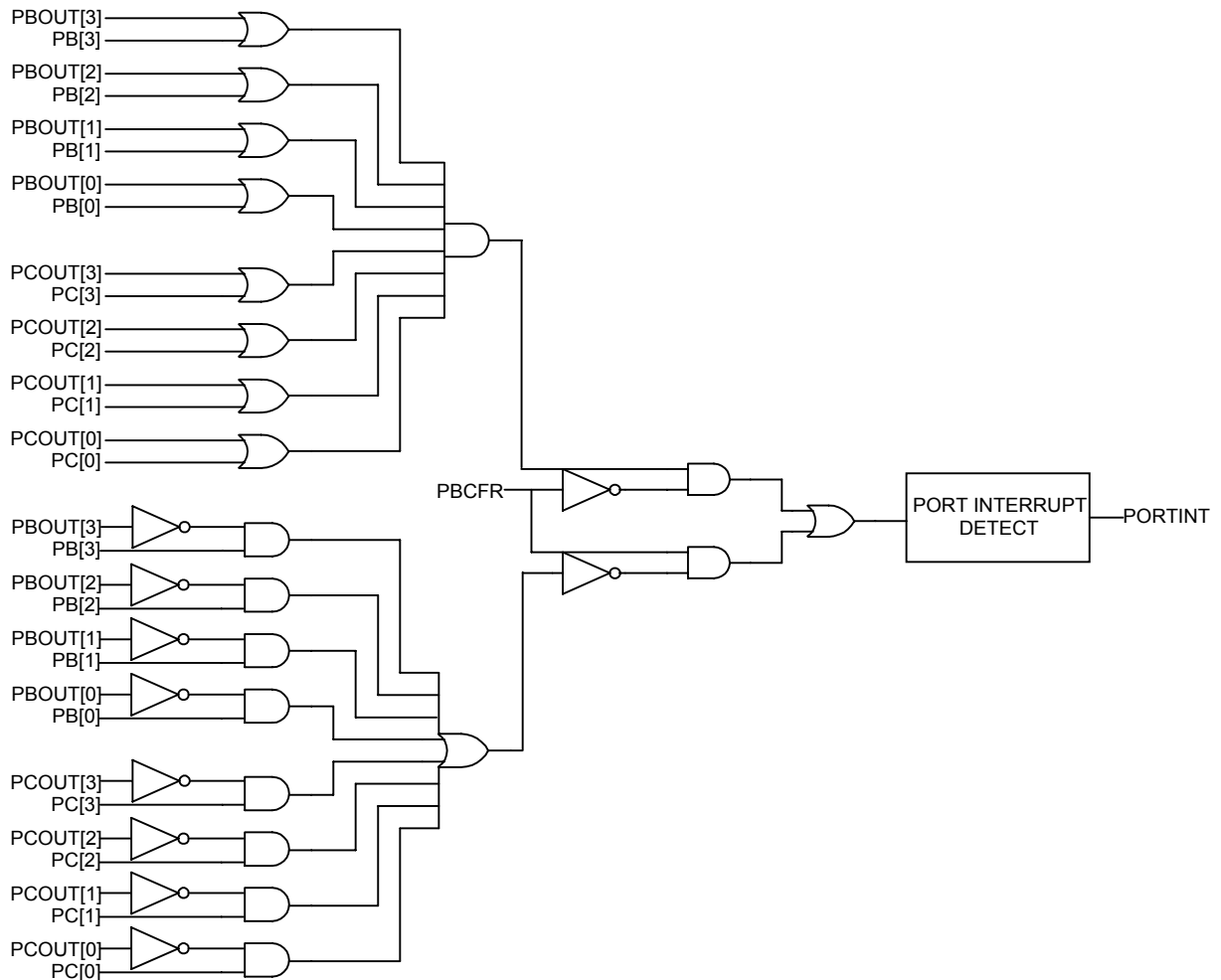



6. T0 & WDT

System Register \$1C

Address	BIT3	BIT2	BIT1	BIT0	R/W	Remark
\$1C	-	-	T0S	T0E	W	Bit0: T0 signal edge Bit1: T0 signal source

T0E: T0 signal edge

0: Increment on low-to-high transition T0 pin (Power on initial)

1: Increment on high-to-low transition T0 pin

T0S: T0 signal source.

0: OSC 1/4 (Power on initial).

1: Transition on T0 pin.

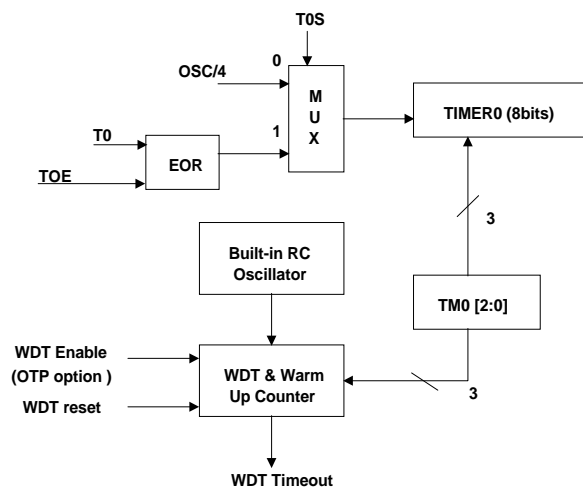



System Register \$1E

Address	Bit3	Bit2	Bit1	Bit0	R/W	Remark
\$1E	WDT	-	-	-	W	Bit3: Watchdog timer reset. (write 1 to reset WDT)

The input clock of the watchdog timer is generated by a built-in RC oscillator so that the WDT will always run even in the STOP mode. SH69P25 generates a RESET condition when the watchdog times-out. The watchdog can be enabled or disabled permanently by using the OTP option. To prevent it timing out and generating a device RESET condition, you should write this bit as “1” before timing-out. The WDT has a time-out period of more than 7ms(typical 18ms) . If longer time-out periods are desired, a prescaler with a division ratio of up to 1:2048 can be assigned to the WDT under software control by writing to the TMO register.

Pre-scaler divide ratio:

TM0.2	TM0.1	TM0.0	Prescaler Divide Ratio	Timer-out Period
1	1	1	1:1	7ms(min)
1	1	0	1:2	14ms(min)
1	0	1	1:4	28ms(min)
1	0	0	1:8	56ms(min)
0	1	1	1:32	224ms(min)
0	1	0	1:128	896ms(min)
0	0	1	1:512	3,584ms(min)
0	0	0	1:2048 (Power on initial)	14,336ms(min)

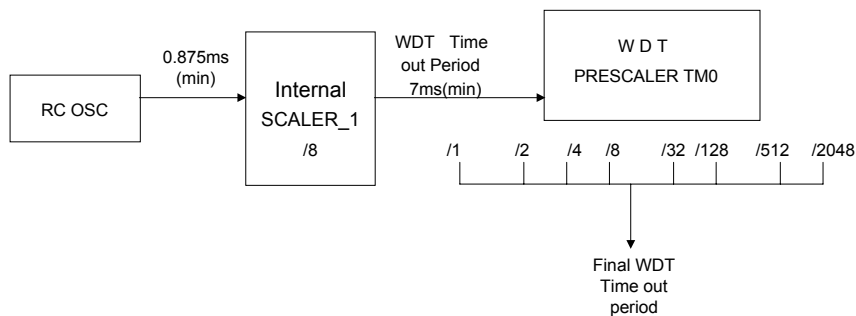



7. Timer0

SH69P25 has one 8-bit timer. The time/counter has the following features:

- . 8-bit timer/counter
- . Readable and writeable
- . Automatic reloadable counter
- . 8-prescaler scale is available
- . Internal and external clock select
- . Interrupt on overflow from \$FF to \$00
- . Edge select for external event

Following is a simplified timer block diagram:

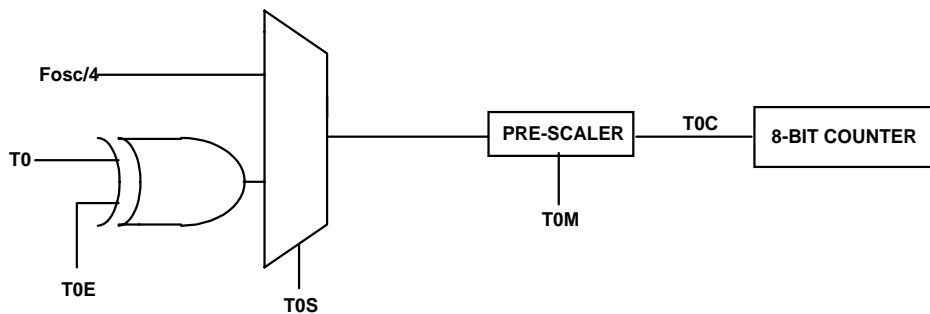

7.1. Configuration and Operation

Timer0 consists of an 8-bit write-only timer load register (TL0L, TL0H), and an 8-bit read-only timer counter (TC0L, TC0H). The counter and load register both have low order digits and high order digits. Writing data into the timer load register (TL0L, TL0H) can initialize the timer counter. Load register programming: Write the low-order digit first and then the high-order digit. The timer counter is loaded with the contents of the load register automatically when the high order digit is written or the counter counts overflow from \$FF to \$00.

Timer Load Register: Since the register H controls the physical READ and WRITE operation, please follow these rules:

Write Operation:

- First write Low nibble,
- Then write High nibble to update the counter.

Read Operation:

- High nibble first;
- Followed by Low nibble.

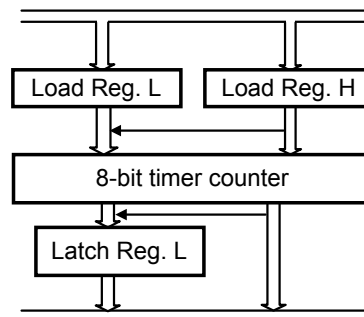



7.2. Timer0 Interrupt

The timer overflow will generate an internal interrupt request, when the counter counts overflow from \$FF to \$00. If the interrupt enable flag is enabled, then a timer interrupt service routine will proceed. This can also be used to waken the CPU from HALT mode.

7.3. Timer0 Mode Register

The timer can be programmed in several different prescaler ratios by setting the Timer Mode register (TM0). The 8-bit counter counts prescaler overflow output pulses. The timer mode registers (TM0) are 3-bit registers used for timer control as shown in table1. These mode registers select the input pulse sources into the timer.

Table 1. Timer 0 Mode Register (\$02)

TM0.2	TM0.1	TM0.0	Prescaler Divide Ratio	Ratio N
0	0	0	$1/2^{11}$	2048 (initial)
0	0	1	$1/2^9$	512
0	1	0	$1/2^7$	128
0	1	1	$1/2^5$	32
1	0	0	$1/2^3$	8
1	0	1	$1/2^2$	4
1	1	0	$1/2^1$	2
1	1	1	$1/2^0$	1

7.4. External Clock/Event T0 as Timer0 Source

When an external clock/event input is used for the TM0, it is synchronized with the CPU system clock. Therefore the external source must follow certain constraints. The output from the T0M multiplex is T0C. It is sampled by the system clock in instruction frame cycle. Therefore it is necessary for the T0C to be high (at least 2 *tosc*) and low (at least 2 *tosc*). When the prescaler ratio selects $1/2^0$, the T0C is the same as the system clock input. Therefore the requirement is as follows

$$T0H = T0CH = T0 \text{ high time} \geq 2 \text{ } t_{osc} + \Delta T$$

$$T0L = T0CL = T0 \text{ low time} \geq 2 \text{ } t_{osc} + \Delta T$$

Note: $\Delta T = 40\text{ns}$

When another prescaler ratio is selected, the TM0 is scaled by the asynchronous ripple counter and so the prescaler output is symmetrical.

Then:

$$T0C \text{ high time} = T0C \text{ low time} = \frac{N * T0}{2}$$

Where

T0 = Timer0 input period

N = prescaler value

The requirement is, therefore:

$$\frac{N * T0}{2} \geq 2 \text{ } t_{osc} + \Delta T, \text{ or } T0 \geq \frac{4 * t_{osc} + 2\Delta T}{N}$$

The limitation is applied for the T0 period time only. The pulse width is not limited by this equation. It is summarized as follows:

$$T0 = \text{Timer0 period} \geq \frac{4 * t_{osc} + 2\Delta T}{N}$$



8. System Clock and Oscillator

System clock generator produces the basic clock pulses that provide the system clock to the CPU and any peripherals.
Instruction cycle time

- (1) $4/32.768\text{kHz}$ ($\approx 122\mu\text{s}$) for 32.768kHz system clock
- (2) $4/4\text{MHz}$ (1 μs) for 4MHz system clock

8.1 Oscillator type

- (1) Crystal oscillator: 32.768kHz – 4MHz.

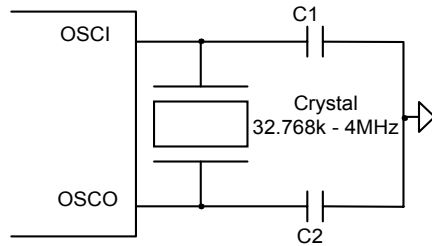

- (2) Ceramic resonator: 400kHz – 4MHz.

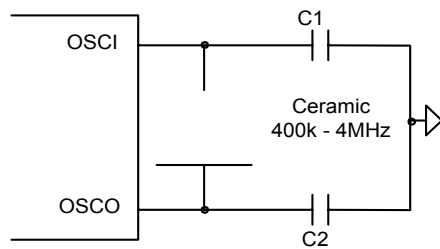

- (3) RC oscillator: 400kHz – 4MHz.

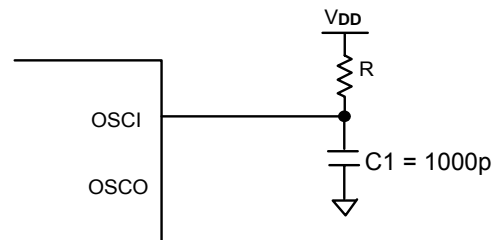

- (4) External input clock: 30kHz – 4MHz.

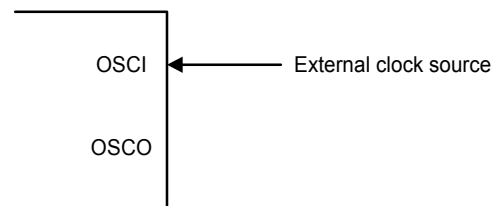



9. OTP option

- (a). Oscillator range
 - 0: OSC @ 32K~2MHz (default)
 - 1: OSC @ 2M ~ 4MHz
- (b). LPD voltage range
 - 0: High LPD voltage (default)
 - 1: Low LPD Voltage
- (c): LPD on/off control
 - 0: LPD off (default)
 - 1: LPD on
- (d): WDT on/off control
 - 0: WDT on (default)
 - 1: WDT off
- (e): Oscillator select:
 - 000: External clock (default)
 - 100: RC Oscillator 400k~4M
 - 110: Crystal /Ceramic Resonator 400k~4M
 - 111: X'tal 32768Hz

10. In System Programming Notice for OTP

For COB(chip on Board) assembling mode, the In System Programming technology is valid for OTP chip of SinoWealth Co.. The Programming Interface of OTP chip must be left on user's application PCB, and users can assemble all components including OTP chip in application PCB before programming OTP chip first. Of course it is accessible that bonding OTP chip only first, then programming code, and assembling the others components at last. Because the programming timing of Programming Interface is very sensitive, so four jumpers are needed (VDD, VPP, SDA, SCK) to separate programming pins from application circuit just as following diagram.

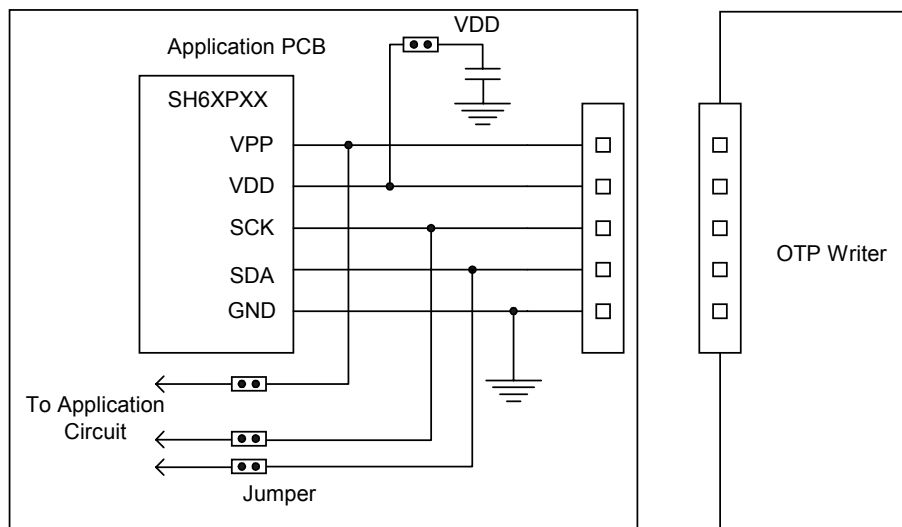

The recommended step is as following for these jumpers:

- 1) The jumper is Open to separate programming pins from application circuit before programming code.
- 2) Connect the programming interface with OTP Writer and Begin Programming code.
- 3) Disconnect OTP writer and short these jumpers when programming is finished.

For more detail information please refer to the OTP writer user manual.



Instruction Set

All instructions are one cycle and one-word instructions. The characteristic is memory-oriented operation.

Arithmetic and Logical Instruction

Accumulator Type

Mnemonic	Instruction Code	Function	Flag Change
ADC X (, B)	00000 0bbb xxx xxxx	AC ← Mx + AC + CY	CY
ADCM X (, B)	00000 1bbb xxx xxxx	AC, Mx ← Mx + AC + CY	CY
ADD X (, B)	00001 0bbb xxx xxxx	AC ← Mx + AC	CY
ADDM X (, B)	00001 1bbb xxx xxxx	AC, Mx ← Mx + AC	CY
SBC X (, B)	00010 0bbb xxx xxxx	AC ← Mx + -AC + CY	CY
SBCM X (, B)	00010 1bbb xxx xxxx	AC, Mx ← Mx + -AC + CY	CY
SUB X (, B)	00011 0bbb xxx xxxx	AC ← Mx + -AC + 1	CY
SUBM X (, B)	00011 1bbb xxx xxxx	AC, Mx ← Mx + -AC + 1	CY
EOR X (, B)	00100 0bbb xxx xxxx	AC ← Mx ⊕ AC	
EORM X (, B)	00100 1bbb xxx xxxx	AC, Mx ← Mx ⊕ AC	
OR X (, B)	00101 0bbb xxx xxxx	AC ← Mx AC	
ORM X (, B)	00101 1bbb xxx xxxx	AC, Mx ← Mx AC	
AND X (, B)	00110 0bbb xxx xxxx	AC ← Mx & AC	
ANDM X (, B)	00110 1bbb xxx xxxx	AC, Mx ← Mx & AC	
SHR	11110 0000 000 0000	0 → AC[3]; AC[0] → CY; AC shift right one bit	CY

Immediate Type

Mnemonic	Instruction Code	Function	Flag Change
ADI X, I	01000 iiiiii xxx xxxx	AC ← Mx + I	CY
ADIM X, I	01001 iiiiii xxx xxxx	AC, Mx ← Mx + I	CY
SBI X, I	01010 iiiiii xxx xxxx	AC ← Mx + -I + 1	CY
SBIM X, I	01011 iiiiii xxx xxxx	AC, Mx ← Mx + -I + 1	CY
EORIM X, I	01100 iiiiii xxx xxxx	AC, Mx ← Mx ⊕ I	
ORIM X, I	01101 iiiiii xxx xxxx	AC, Mx ← Mx I	
ANDIM X, I	01110 iiiiii xxx xxxx	AC, Mx ← Mx & I	

Decimal Adjustment

Mnemonic	Instruction Code	Function	Flag Change
DAA X	11001 0110 xxx xxxx	AC; Mx ← Decimal adjustment for add.	CY
DAS X	11001 1010 xxx xxxx	AC; Mx ← Decimal adjustment for sub.	CY



Transfer Instructions

Mnemonic	Instruction Code	Function	Flag Change
LDA X (, B)	00111 0bbb xxx xxxx	AC ← Mx	
STA X (, B)	00111 1bbb xxx xxxx	Mx ← AC	
LDI X, I	01111 iii xxx xxxx	AC, Mx ← I	

Control Instructions

Mnemonic	Instruction Code	Function	Flag Change
BAZ X	10010 xxxx xxx xxxx	PC ← X if AC = 0	
BNZ X	10000 xxxx xxx xxxx	PC ← X if AC ≠ 0	
BC X	10011 xxxx xxx xxxx	PC ← X if CY = 1	
BNC X	10001 xxxx xxx xxxx	PC ← X if CY ≠ 1	
BA0 X	10100 xxxx xxx xxxx	PC ← X if AC(0) = 1	
BA1 X	10101 xxxx xxx xxxx	PC ← X if AC(1) = 1	
BA2 X	10110 xxxx xxx xxxx	PC ← X if AC(2) = 1	
BA3 X	10111 xxxx xxx xxxx	PC ← X if AC(3) = 1	
CALL X	11000 xxxx xxx xxxx	ST ← CY; PC + 1 PC ← X (Not including p)	
RTNW H, L	11010 000h hhh llll	PC ← ST; TBR ← hhhh; AC ← llll	
RTNI	11010 1000 000 0000	CY; PC ← ST	CY
HALT	11011 0000 000 0000		
STOP	11011 1000 000 0000		
JMP X	1110p xxxx xxx xxxx	PC ← X (Including p)	
TJMP	11110 1111 111 1111	PC ← (PC11-PC8) (TBR) (AC)	
NOP	11111 1111 111 1111	No Operation	

Where,

PC	Program counter	I	Immediate data
AC	Accumulator	⊕	Logical exclusive OR
-AC	Complement of accumulator		Logical OR
CY	Carry flag	&	Logical AND
Mx	Data memory	bbb	RAM bank
p	ROM page	B	RAM bank. Every \$7F as one RAM bank.
ST	Stack	TBR	Table Branch Register



Absolute Maximum Rating*

DC Supply Voltage -0.3V to + 7.0V
 Input Voltage -0.3V to V_{DD} + 0.3V
 Operating Ambient Temperature . . . -40 to + 85
 Storage Temperature -55 to + 125

***Comments**

Stresses above those listed under “Absolute Maximum Ratings” may cause permanent damage to this device. These are stress ratings only. Functional operation of this device under these or any other conditions above those indicated in the operational sections of this specification is not implied or intended. Exposure to the absolute maximum rating conditions for extended periods may affect device reliability.

DC Electrical Characteristics (V_{DD} = 5.0V GND = 0V, T_A = 25 , Fosc = 4MHz, unless otherwise specified)

Parameter	Symbol	Min.	Typ.	Max.	Unit	Condition
Operating Voltage	V _{DD}	4.5	5.0	6.0	V	
Operating Current	I _{OP}		0.6	1.0	mA	All output pins unloaded (Execute NOP instruction)
Stand by Current (HALT)	I _{SB1}			0.5	mA	All output pins unloaded
Stand by Current (STOP)	I _{SB2}			1	μA	All output pins unloaded, LPD off (If LPD on, I _{SB2X} = I _{SB2} + 2μA) WDT off (If WDT on, I _{SB2X} = I _{SB2} + 15μA)
Input Low Voltage	V _{IL1}	GND		0.2 X V _{DD}	V	I/O ports, pins tri-state
Input Low Voltage	V _{IL2}	GND		0.15 X V _{DD}	V	RESET , T0
Input Low Voltage	V _{IL3}	GND		0.15 X V _{DD}	V	OSCI (Driven by external clock)
Input High Voltage	V _{IH1}	0.8 X V _{DD}		V _{DD}	V	I/O ports, pins tri-state
Input High Voltage	V _{IH2}	0.85 X V _{DD}		V _{DD}	V	RESET , T0
Input High Voltage	V _{IH3}	0.85 X V _{DD}		V _{DD}	V	OSCI (Driven by external Clock)
Input Leakage Current	I _{IL1}	-1		1	μA	I/O ports, GND < V _{I/O} < V _{DD}
Input Leakage Current	I _{IL2}	-5			μA	V _{RESET} = GND + 0.25V
Input Leakage Current	I _{IL3}		1	5	μA	V _{RESET} = V _{DD}
Input Leakage Current	I _{IL4}	-3	1	3	μA	T0, GND < V _{I0} < V _{DD}
Input Leakage Current	I _{IL5}	-3	1	3	μA	For OSCI
Pull-up/ Pull-low Resistor	R _P		150		KΩ	PULL-UP/ PULL-LOW resistor
Output High Voltage	V _{OH}	V _{DD} - 0.7			V	I/O ports, I _{OH} = -10mA
Output Low Voltage	V _{OL}			GND + 0.6	V	I/O ports, I _{OL} = 20mA

AC Electrical Characteristics (V_{DD} = 5.0V GND = 0V, T_A = 25 , unless otherwise specified)

Parameter	Symbol	Min.	Typ.	Max.	Unit	Condition
Oscillator Start Time	T _{OSC1}			1	s	X'tal osc = 32.768KHz
RESET pulse width (low)	T _{RESET}	10			μs	V _{DD} = 5.0V
WDT Period	T _{WDT}	7	18		ms	V _{DD} = 5.0V
Frequency Stability (RC)	Δ F/F			20	%	RC Oscillator: [F(5.0)-F(4.5)]/F(5.0)



DC Electrical Characteristics ($V_{DD} = 3.0V$, $GND = 0V$, $T_A = 25$, $F_{osc} = 4MHz$, unless otherwise specified)

Parameter	Symbol	Min.	Typ	Max.	Unit	Condition
Operating Voltage	V_{DD}	2.4	3.0	4.5	V	
Operating Current	I_{OP}		0.3	0.6	mA	All output pins unloaded (Execute NOP instruction)
Stand by Current (HALT)	I_{SB1}			0.2	mA	All output pins unloaded
Stand by Current (STOP)	I_{SB2}			1	μA	All output pins unloaded, LPD off (If LPD on, $I_{SB2X} = I_{SB2} + 2\mu A$) WDT off (If WDT on, $I_{SB2X} = I_{SB2} + 5\mu A$)
Input Low Voltage	V_{IL1}	GND		$0.2 \times V_{DD}$	V	I/O ports, pins tri-state
Input Low Voltage	V_{IL2}	GND		$0.15 \times V_{DD}$	V	\overline{RESET} , T0
Input Low Voltage	V_{IL3}	GND		$0.15 \times V_{DD}$	V	OSCI (Driven by external clock)
Input High Voltage	V_{IH1}	$0.8 \times V_{DD}$		V_{DD}	V	I/O ports, pins tri-state
Input High Voltage	V_{IH2}	$0.85 \times V_{DD}$		V_{DD}	V	\overline{RESET} , T0
Input High Voltage	V_{IH3}	$0.85 \times V_{DD}$		V_{DD}	V	OSCI (Driven by external Clock)
Input Leakage Current	I_{IL1}	-1		1	μA	I/O ports, $GND < V_{i/o} < V_{DD}$
Input Leakage Current	I_{IL2}	-5			μA	$V_{\overline{RESET}} = GND + 0.25V$
Input Leakage Current	I_{IL3}		1	5	μA	$V_{\overline{RESET}} = V_{DD}$
Input Leakage Current	I_{IL4}	-3	1	3	μA	T0, $GND < V_{t0} < V_{DD}$
Input Leakage Current	I_{IL5}	-3	1	3	μA	For OSCI
Output High Voltage	V_{OH}	$V_{DD} - 0.7$			V	I/O ports, $I_{OH} = -7mA$, $V_{DD} = 3V$
Output Low Voltage	V_{OL}			$GND + 0.4$	V	I/O ports, $I_{OL} = 8mA$, $V_{DD} = 3V$

User Notice:

Max. Current into $V_{DD} = 100mA$;
 Max. Current out of $V_{SS} = 150mA$
 Max. Output current sunk by any I/O port = 50mA;
 Max. Output current sourced by any I/O port = 40mA

AC Electrical Characteristics ($V_{DD} = 3.0V$, $GND = 0V$, $T_A = 25$, unless otherwise specified)

Parameter	Symbol	Min.	Typ	Max.	Unit	Condition
Oscillator Start Time	T_{OSC1}			1	s	Crystal Osc = 32.768KHz, $V_{DD} = 3.0V$
RESET pulse width (low)	T_{RESET}	12			μs	$V_{DD} = 3.0V$
WDT Period	T_{WDT}	7	18		ms	$V_{DD} = 3.0V$
Frequency Stability (RC)	$\Delta F/F$			20	%	RC oscillator (1MHz): $[F(3.0)-F(2.7)]/F(3.0)$

Low Power Detect Electrical Characteristics

(a) $V_{DD} = 2.4\sim 6V$, $GND = 0V$, $T_A = 25^\circ C$, $F_{osc} = 4MHz$, unless otherwise specified.

Parameter	Symbol	Min.	Typ	Max.	Unit	Condition
LPD Voltage(Low)	V_{LPD1}	2.3	2.5	2.7	V	LPD enable
LPD Voltage(High)	V_{LPD2}	3.8	4.0	4.2	V	LPD enable
Low power detect ignore time	t_{LPD}	100	300	500	μs	LPD enable and $V_{DD} < V_{LPD}$



AC Characteristics

Symbol	Parameter	Min.	Typ.	Max.	Unit	Condition
Tcy	Instruction Cycle Time	1		122	μs	
Tiw	T0 Input Width	$(Tcy + 40)/N$			ns	N = Prescaler divide ratio
Tiwh	High Pulse Width	1/2 tiw			ns	
Tiwl	LOW Pulse Width	1/2 tiw			ns	

Timing Waveform

T0 Input Waveform

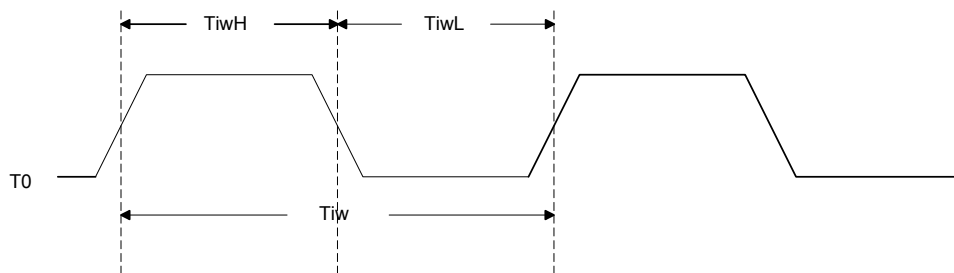

Built-in RC Oscillator (Only use for Watch Dog)

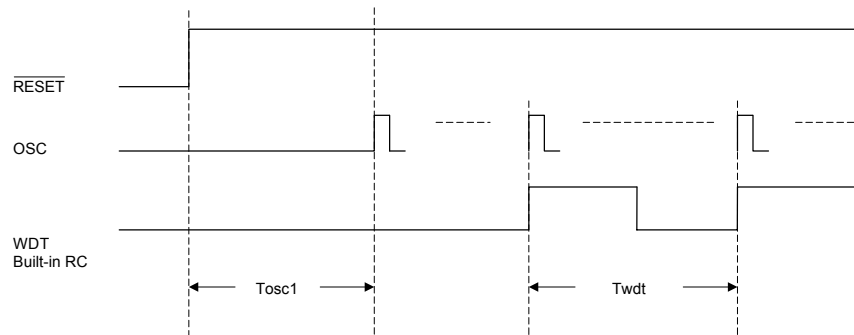



Typical RC oscillator Resistor vs. Frequency: ($V_{DD} = 5V$, for reference only)

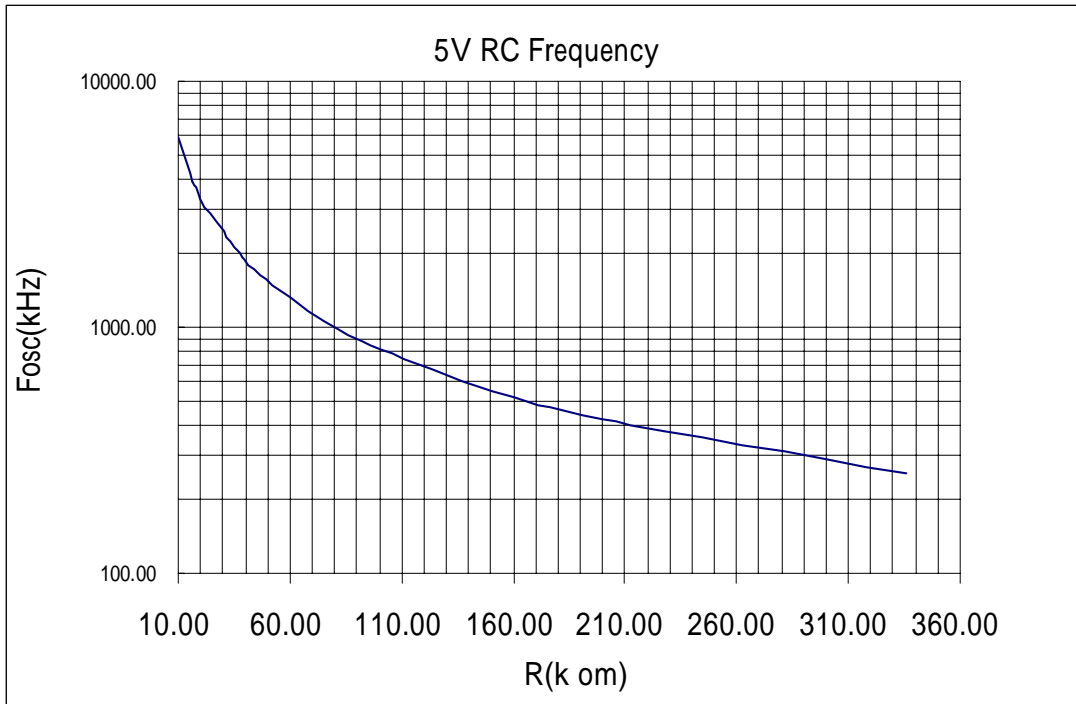

Typical RC Oscillator Resistor vs. Frequency: ($V_{DD} = 3V$, for reference only)

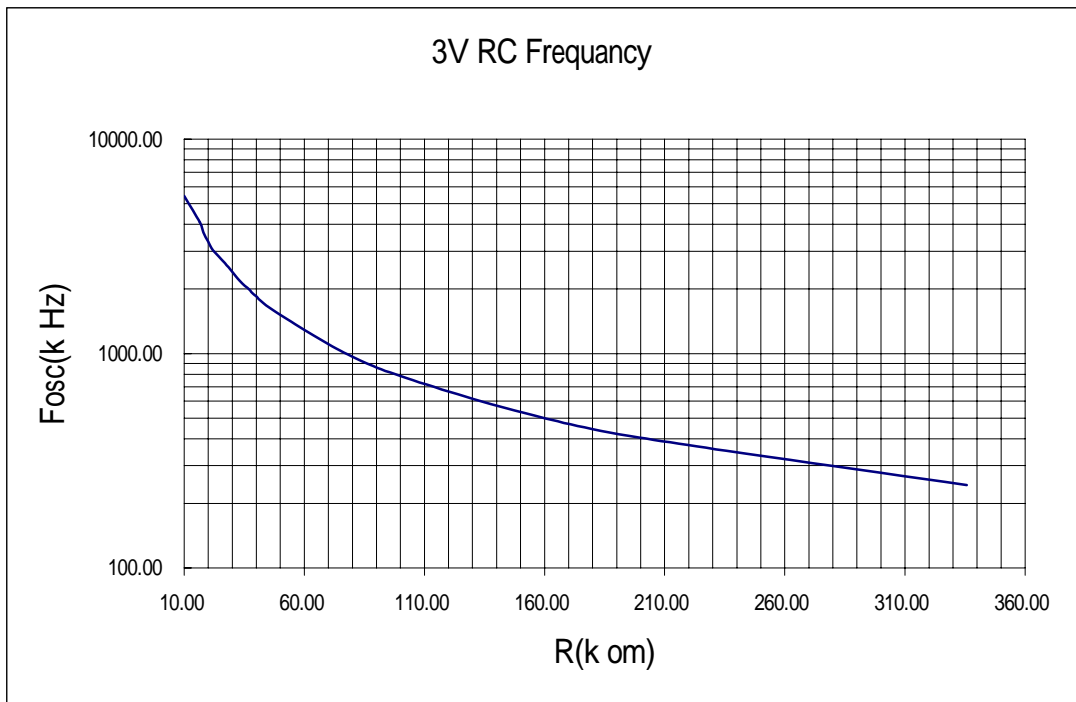



Application Circuit (for reference only)

AP1

- (1) Operating voltage: 5.0V
- (2) Oscillator: Ceramic resonator 400kHz
- (3) T0 input timer clock / counter
- (4) PORTA – F: I/O

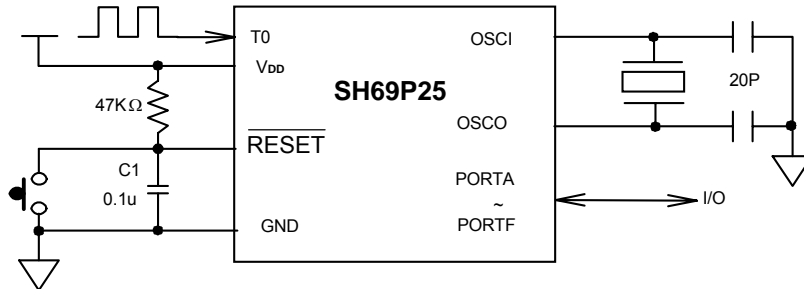

AP2

- (1) Operating voltage: 5.0V.
- (2) Oscillator: RC 400KHz.
- (3) PORTA – E: I/O

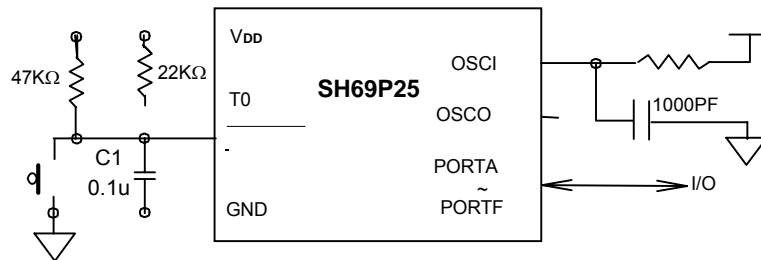



AP3

- (1) PORTA – C: as scan KEY BOARD (32 keys)
- (2) PORTD – F: I/O,
- (3) All input pin internal Pull up On

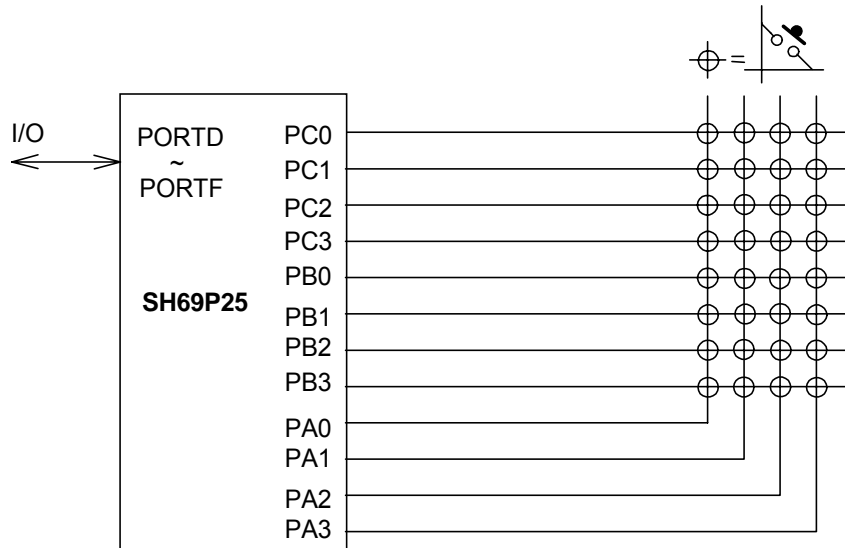



Ap4 (Weight Scale)

- (1) Operating voltage: 5.0V
- (2) Oscillator: Ceramic resonator 4MHz
- (3) Port A0: External interrupt input for ON/OFF switch
- (4) Port E2, E3, F1, A2: S4 – S1 analog switch control signals that control V_{il} is being charged or discharged by both the reference voltage (V_{ref}) and the amplified voltage (V_o). The charging and discharging times are determined by the values of $C1$, $R4$ and the threshold voltage of the T_0 input pin and the ADC resolution can be up to 8 bit
- (5) Other Ports: Sink seven-segment LED current directly. 0 – 199 can be displayed in this configuration

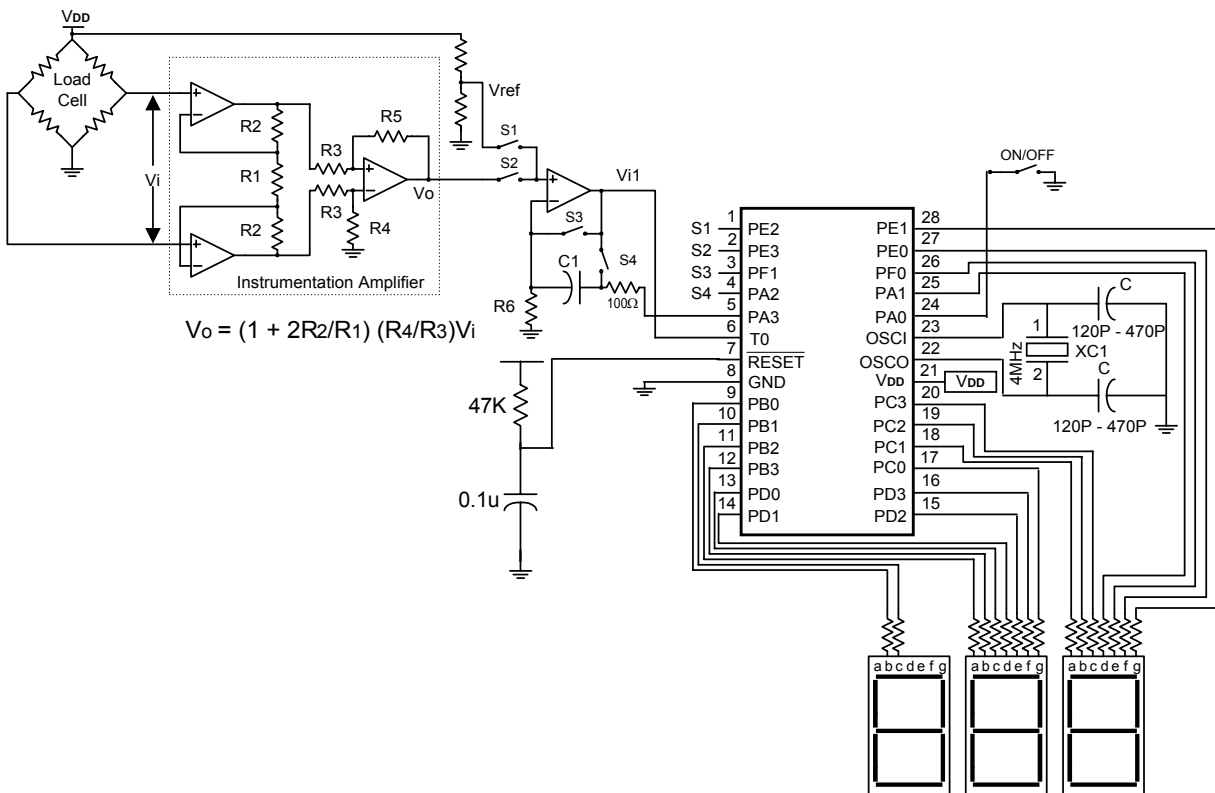



Bonding Diagram

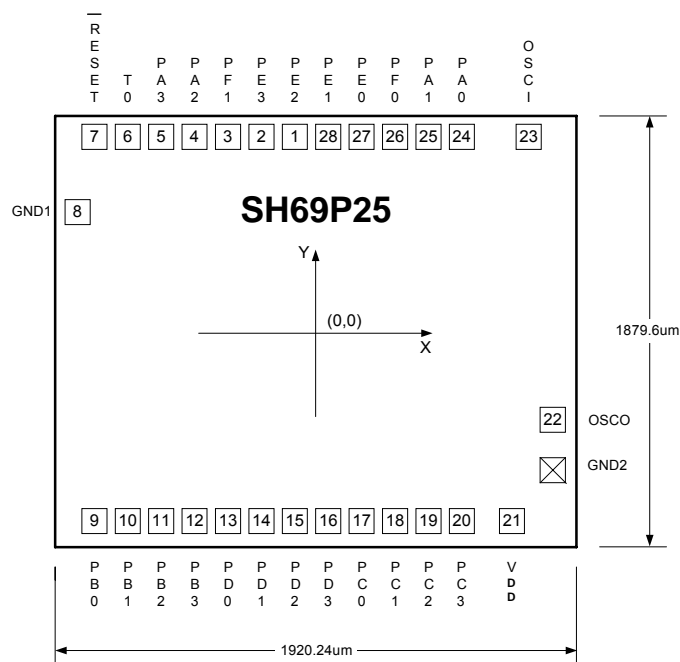

NOTE:

1. GND1 BONDING TO GROUND PIN
2. GND2 BONDING TO SUBSTRATE
3. SUBSTRATE BONDING TO GROUND PIN

Pad Location

unit: μm

Pad No.	Designation	X	Y	Pad No.	Designation	X	Y
1	PE 2	-23	749.5	16	PD 3	114	-749.5
2	PE 3	-153	749.5	17	PC 0	244	-749.5
3	PF 1	-283	749.5	18	PC 1	374	-749.5
4	PA 2	-413	749.5	19	PC 2	504	-749.5
5	PA 3	-543	749.5	20	PC 3	634	-749.5
6	T0	-673	749.5	21	VDD	769	-749.5
7	RESET	-803	749.5		GND2	822	-619.5
8	GND1	-818	585	22	OSCO	725	-420
9	PB 0	-796	-749.5	23	OSCI	767	749.5
10	PB 1	-666	-749.5	24	PA 0	587	749.5
11	PB 2	-536	-749.5	25	PA 1	467	749.5
12	PB 3	-406	-749.5	26	PF 0	347	749.5
13	PD 0	-276	-749.5	27	PE 0	227	749.5
14	PD 1	-146	-749.5	28	PE 1	107	749.5
15	PD 2	-16	-749.5				



Ordering Information

Part No.	Packages
SH69P25H	CHIP FORM
SH69P25K	28L SKINNY
SH69P25M	28L SOP



Package Information

SKINNY_28L Outline Dimensions

unit: inches/mm

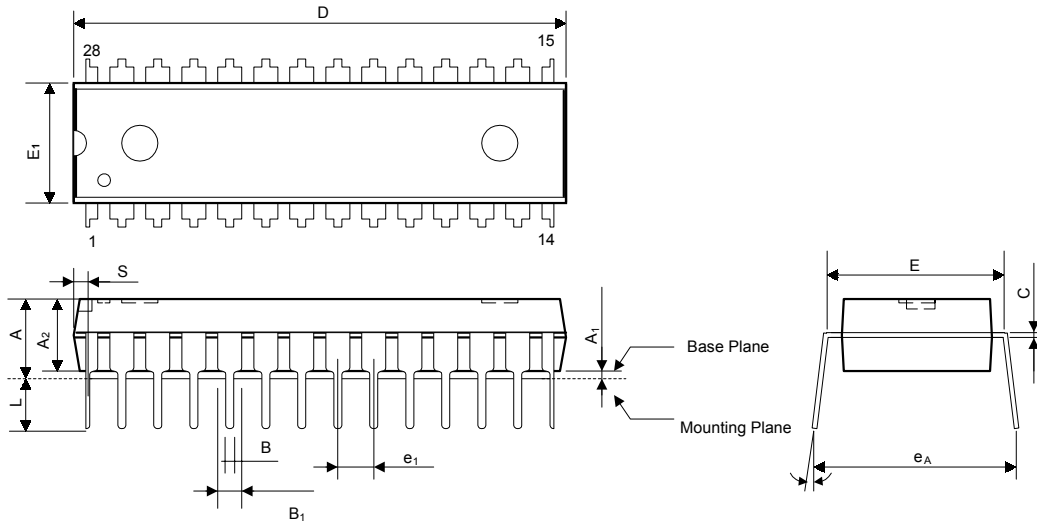

Symbol	Dimensions in inches	Dimensions in mm
A	0.175 Max.	4.45 Max.
A1	0.010 Min.	0.25 Min.
A2	0.130 ± 0.005	3.30 ± 0.13
B	0.018 +0.004 -0.002	0.46 +0.10 -0.05
B1	0.060 +0.004 -0.002	1.52 +0.10 -0.05
C	0.010 +0.004 -0.002	0.25 +0.10 -0.05
D	1.388 Typ. (1.400 Max.)	35.26 Typ. (35.56 Max.)
E	0.310 ± 0.010	7.87 ± 0.25
E1	0.288 ± 0.005	7.32 ± 0.13
e1	0.100 ± 0.010	2.54 ± 0.25
L	0.130 ± 0.010	3.30 ± 0.25
	0° ~ 15°	0° ~ 15°
eA	0.350 ± 0.020	8.89 ± 0.51
S	0.055 Max.	1.40 Max.

Notes:

4. The maximum value of dimension D includes the end flash.
2. Dimension E1 does not include the resin fins.
5. Dimension S includes the end flash.



SOP (N.B.) 28L Outline Dimensions

unit: inches/mm

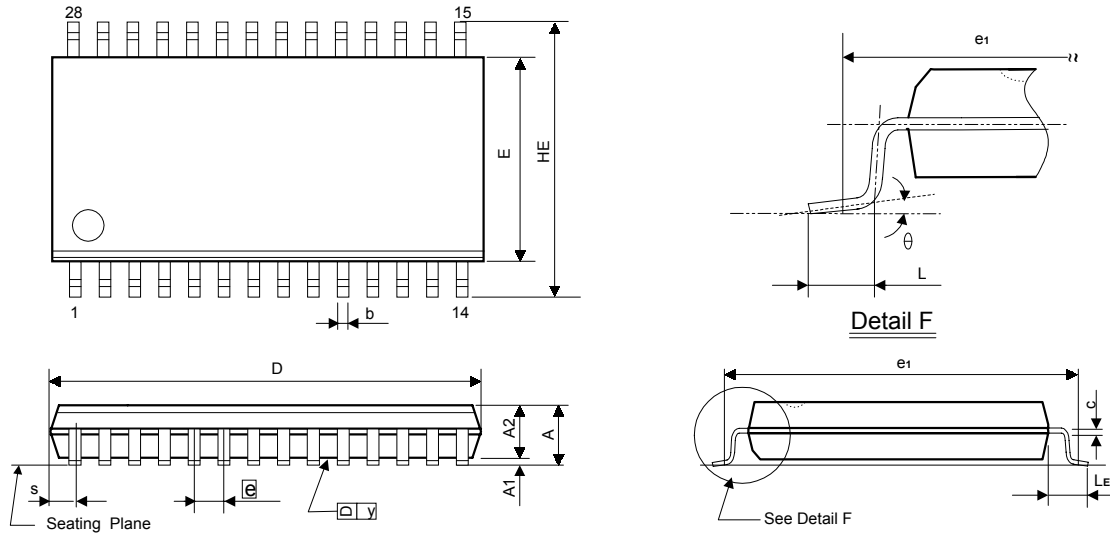

Symbol	Dimensions in inches	Dimensions in mm
A	0.110 Max.	2.79 Max.
A1	0.004 Min.	0.10 Min.
A2	0.093 ± 0.005	2.36 ± 0.13
b	0.016 +0.004 -0.002	0.41 +0.10 -0.05
c	0.010 +0.004 -0.002	0.25 +0.10 -0.05
D	0.705 ± 0.020	17.91 ± 0.51
E	0.295 ± 0.010	7.49 ± 0.25
e	0.050 ± 0.006	1.27 ± 0.15
e ₁	0.376 NOM.	9.40 NOM.
HE	0.406 ± 0.012	10.31 ± 0.31
L	0.036 ± 0.008	0.91 ± 0.20
LE	0.055 ± 0.008	1.40 ± 0.20
S	0.043 Max.	1.09 Max.
y	0.004 Max.	0.10 Max.
θ	0° ~ 10°	0° ~ 10°

Notes:

1. The maximum value of dimension D includes end flash.
2. Dimension E does not include resin fins.
3. Dimension e₁ is for PC Board surface mount pad pitch design reference only.
4. Dimension S includes end flash.



Product Spec. Change Notice

SH69P25 Specification Revision History		
Version	Content	Date
1.01	Change "Max current into VDD pin" from 50mA to 100mA Change "Max. output current sunk by any I/O port " from 25mA to 50mA Change "Max. Output current sourced by any I/O port" from 20mA to 40mA Delete the definition of "Max. Output current sunk by all ports (A, B, C, D, E, F) = 50mA", and "Max. Output current sourced by all ports (A, B, C, D, E, F) = 40mA" Add "In System Programming Notice for OTP"	Nov. 2003
1.0	Reduce operating current. Add RC Frequency-Resistance diagram. Add bonding diagram Change LPD low level voltage range from 2.5±0.1 to 2.5±0.2	May.2003
0.1	Original	Sep.2002